



INSTALLATION INSTRUCTIONS

Accessory
**HARDTOP
TYPE "A"**

Application
**2000 S2000
(SEE VIN RANGE)**



Publications No.
All 22198
Issue Date
APRIL 2001

VIN RANGE

Type "A" hardtop fits all vehicles before this VIN: JHMAP114XYT005730. Check the VIN of your vehicle before proceeding.



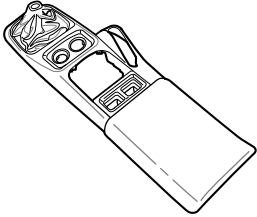
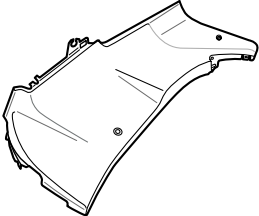
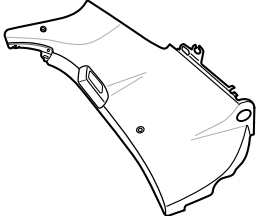
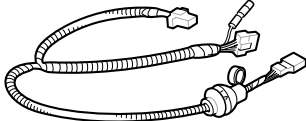
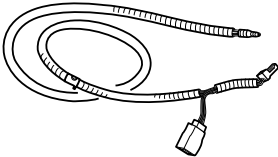

PARTS LIST

**Type "A" Kit (sold separately):
P/N 06690-S2A-KIT-A**

- Center console 
- Left rear side trim 
- Right rear side trim 
- Sub-harness (with 1-pin connector) 
- Rear defroster switch harness 
- Cushion tape 
- 4 Rubber spacers 

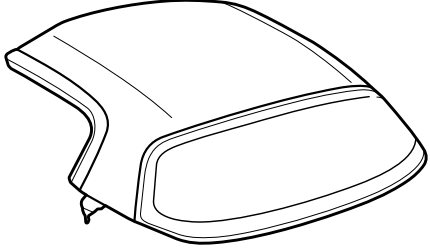
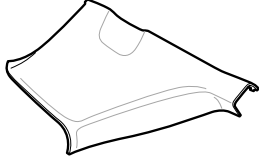
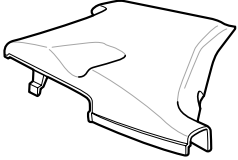
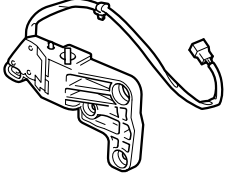
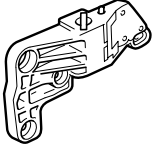
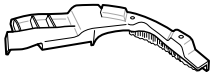
PARTS LIST

Type "B" Kit (sold separately)

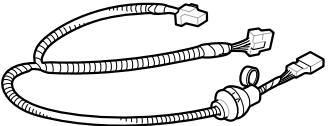
- Hardtop 
- Left rear roof pillar trim 
- Right rear roof pillar trim 
- Left body side catcher 
- Right body side catcher 
- Left side trim brush (not used) 
- Right side trim brush (not used) 
- 2 Front strikers 
- Rear defroster switch 
- Sub-harness (not used) 

Switch cover
(not used)

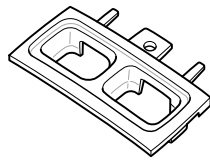

Plastic cover

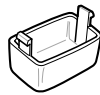

4 Bolts, 6 x 18 mm



4 Bolts, 8 x 20 mm



2 Rubber spacers



4 Cushion spacers



Rear defroster relay

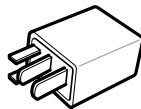

4 Cushion tapes

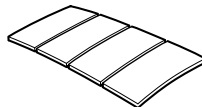

Information label

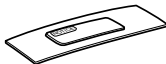

VIN plate

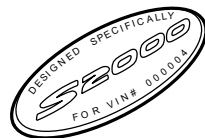

TOOLS AND SUPPLIES REQUIRED

- Small flat-tip screwdriver
- #2 Phillips screwdriver
- Center punch
- Hammer
- Eye protection (face shield, safety goggles, etc.)
- Tape measure
- Felt-tip pen
- Ratchet
- 10 mm, 12 mm, and 14 mm Sockets
- 14 mm Wrench
- Piece of wire
- Isopropyl alcohol
- 3M Weatherstrip adhesive

INSTALLATION

Customer Information: The information in this installation instruction is intended for use only by skilled technicians who have the proper tools, equipment, and training to correctly and safely add equipment to your car. These procedures should not be attempted by "do-it-yourselfers."

1. Unlatch the convertible top, and lower it just past the halfway point.

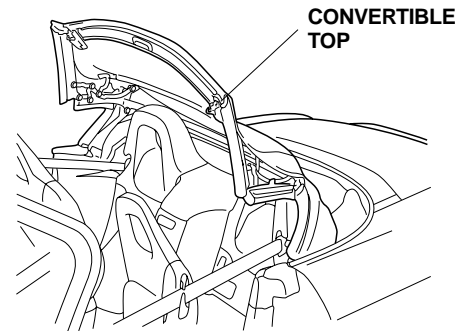

2. Measure the width of the link stopper:
 - **If the width of the link stopper is 10 mm**, apply adhesive to the inside of the rubber spacer and attach it over the link stopper. Repeat on the other side; then lower the convertible top completely.

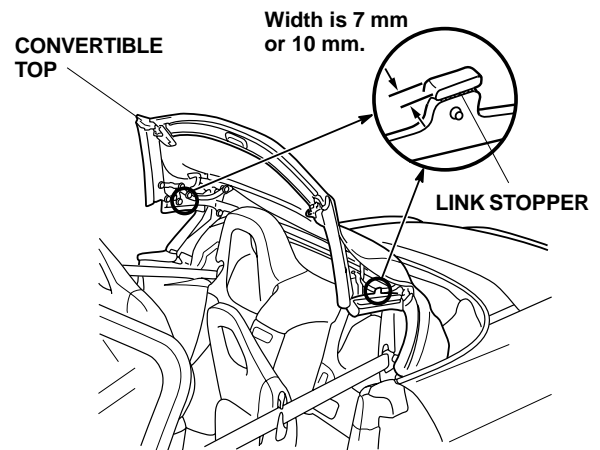

- **If the width of the link stopper is 7 mm,** insert cushion spacers inside the rubber spacer. Remove the adhesive backing from two cushion spacers, and attach them to the inside of the rubber spacer as shown; then apply adhesive to the inside of the rubber spacer, and attach it over the link stopper. Repeat on the other side; then lower the convertible top completely.

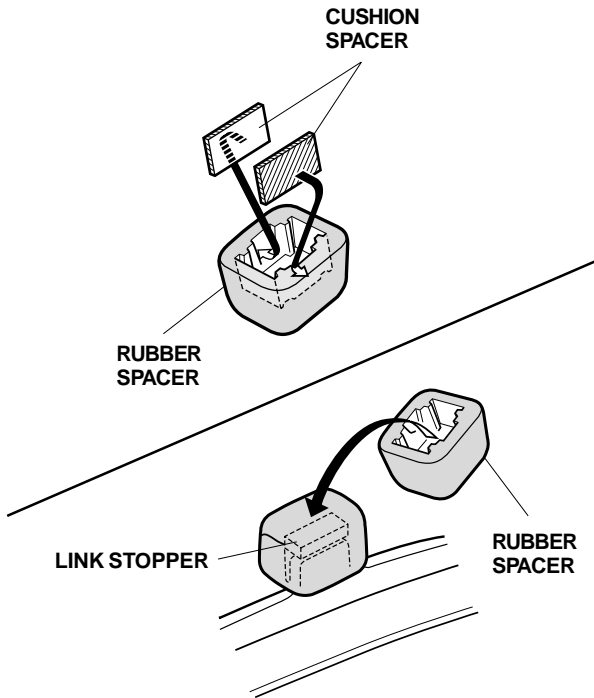

3. Remove the left and right door sill trims (three retaining clips for each side, and rotate the trims inward).

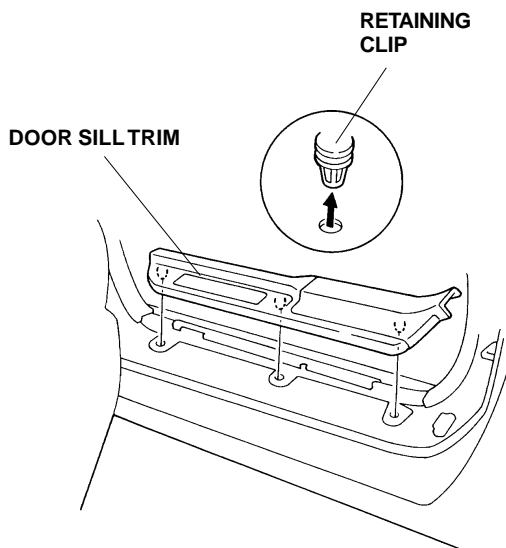

4. Remove the left kick panel (two clips, and carefully remove the hood latch from the panel).

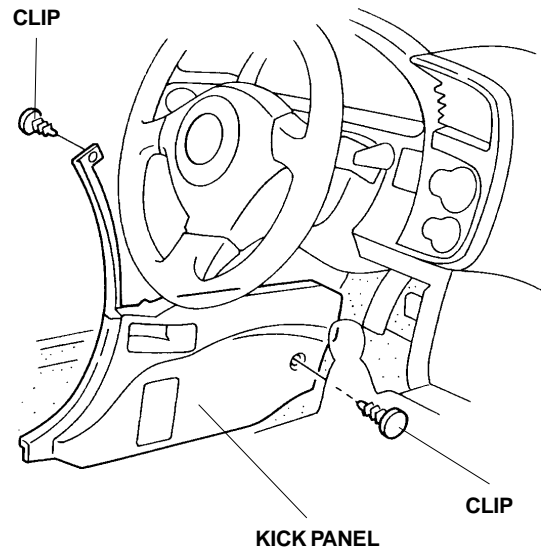

5. Under the dash, locate the under-dash fuse/relay box. Install the relay from the kit into the empty slot shown in the under-dash fuse/relay box.

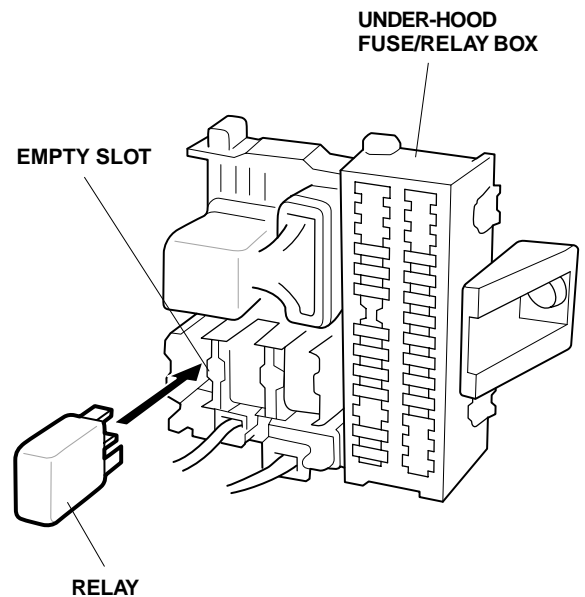

- On each side of the vehicle, remove the roll bar lower trim from the roll bar (two hooks and five retaining tabs).

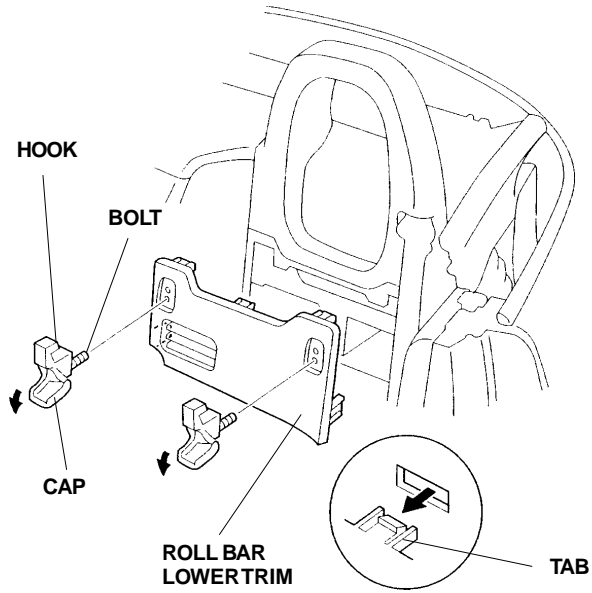

- Remove the left and right rear side trims (one self-tapping screw and one retaining clip for each trim). Set the left and right rear side trims aside; they will not be reused.

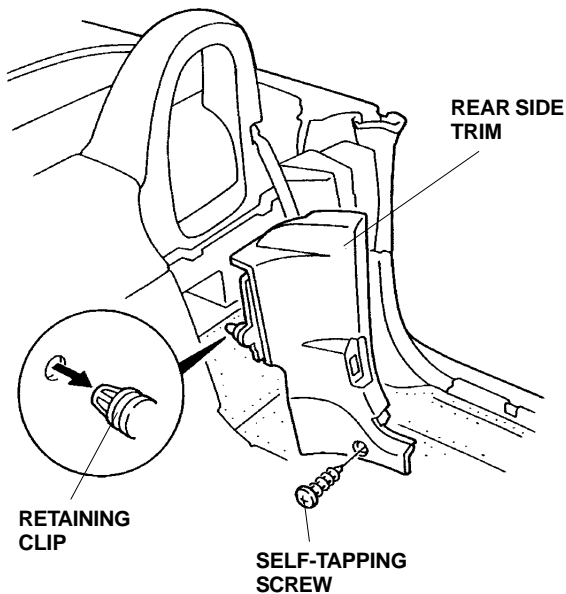

- Open the trunk. Inside the trunk, remove the spare tire cover trim panel (three clips).
- Remove the left trunk side trim (six clips).

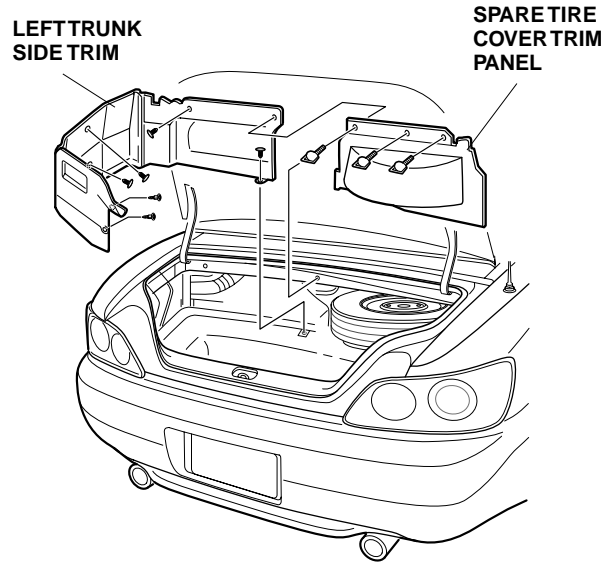

- Inside the trunk, locate the 4-pin connector blue-taped to the vehicle harness. Remove the tape to free the connector. Route the 4-pin connector forward and into the cabin through the opening in the rear bulkhead near the convertible top frame.

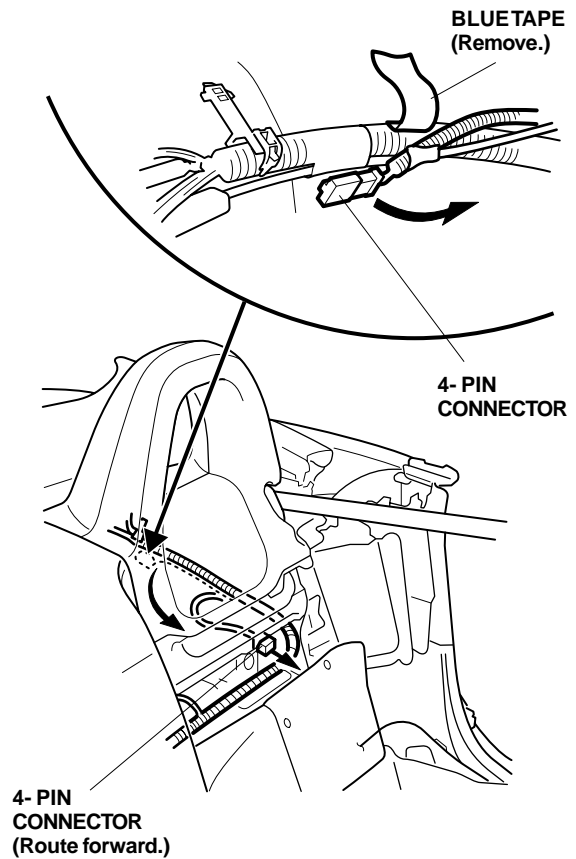

11. Get the sub-harness (with 1-pin connector) from the type "A" kit. Plug the 4-pin connector from the sub-harness into the 4-pin connector you routed into the cabin.

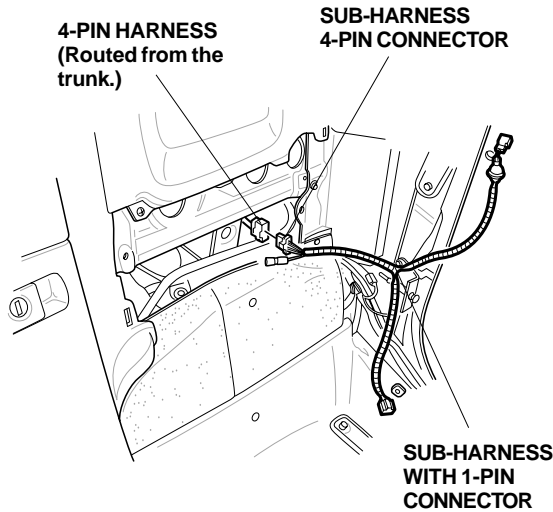

12. Inside the cabin, loosen the locknut, and remove the shift knob.

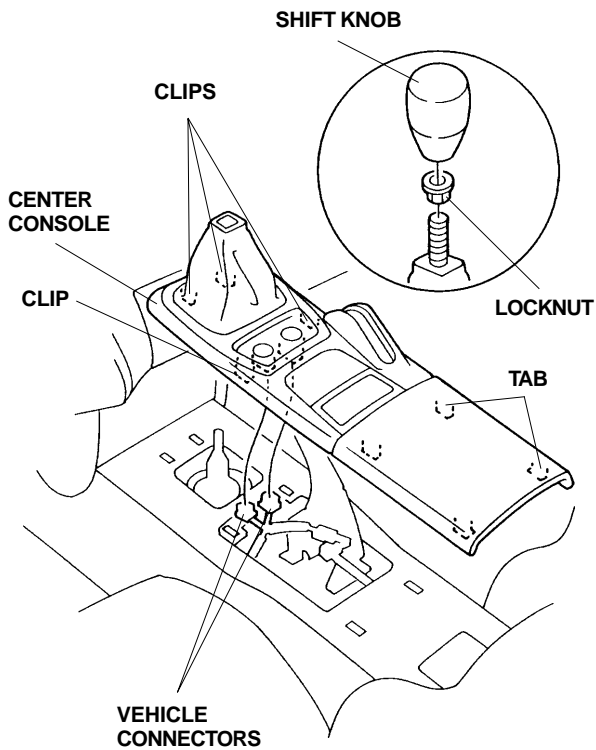

13. Remove the center console (gently lift up to release the eight clips, and unplug the two connectors). If equipped, unplug the LED connectors for the security system.

14. Transfer the cup holder, the hazard warning switch, and the convertible top switch to the new center console included in the type "A" kit. Set the old center console aside; it will not be reused. If equipped, transfer the security system LED to the new center console.

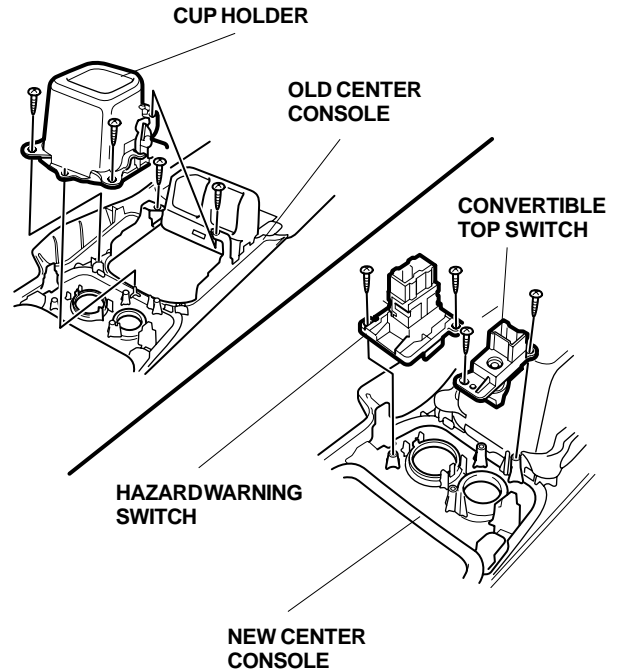

15. Get the rear defroster switch and the plastic cover from type "B" kit, and install them into the switch cover in the new center console.

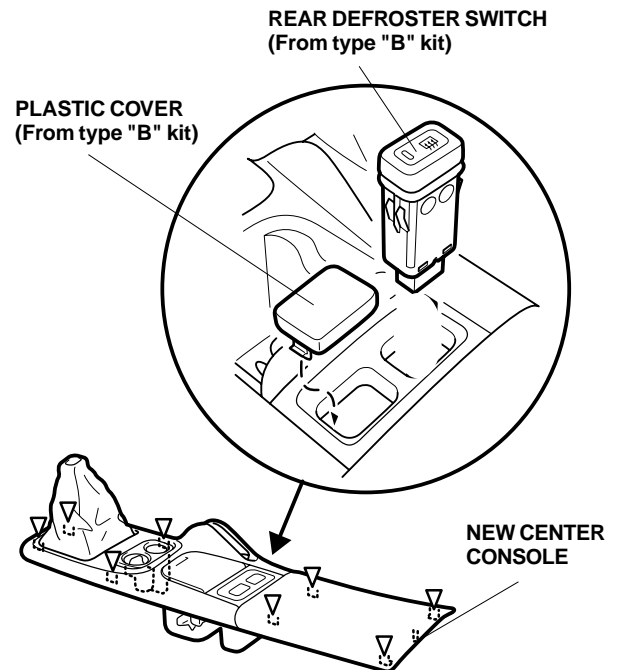

- Near the parking brake, locate the green 5-pin rear defroster connector blue-taped to the vehicle harness. Remove the tape to free the connector.

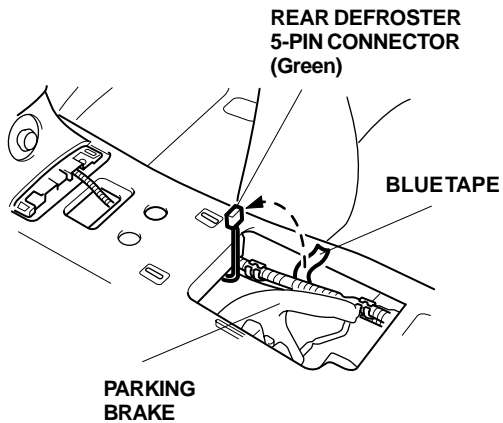

- Get the rear defroster switch harness from the type "A" kit. Plug one 5-pin connector into the rear defroster connector you freed. Route the 1-pin connector rearward through the center console area, under the rear console, and across the rear bulkhead. (The other 5-pin connector will plug into the rear defroster switch.)

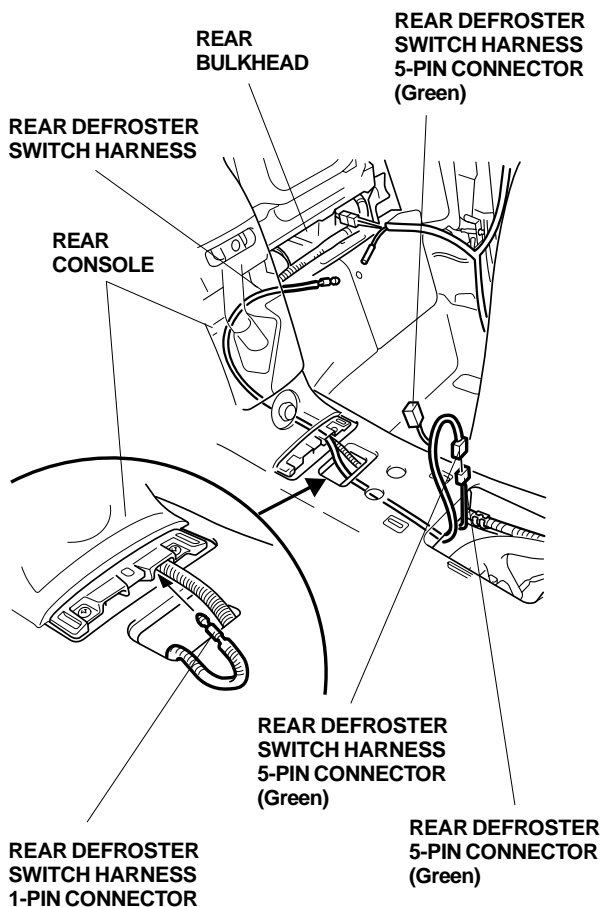

- Plug the rear defroster switch harness 1-pin connector into the sub-harness 1-pin connector installed in step 11. At the Y-connector, route the 2-pin connector downward and the 3-pin connector with rubber boot upward. These connectors will be plugged in later.

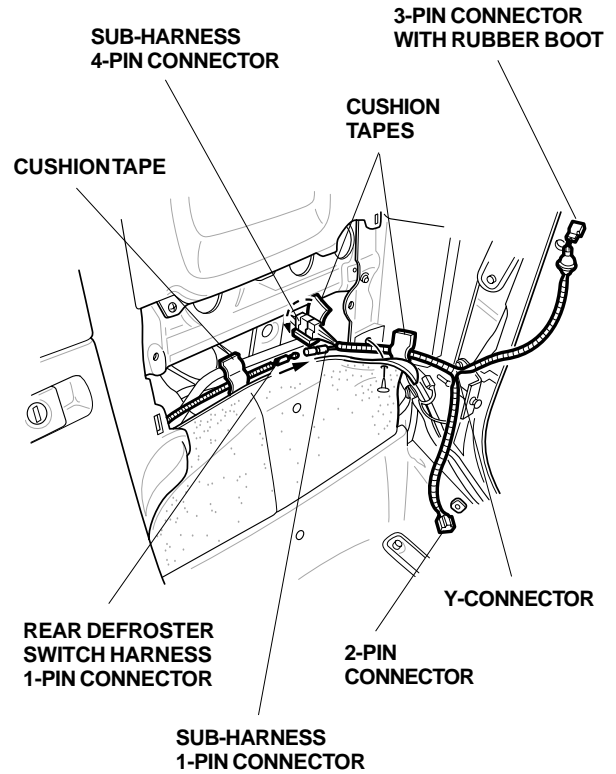

- Wrap one cushion tape around the 4-pin connector, and use two additional cushion tapes to secure the rear defroster switch harness to the vehicle body in the areas shown.
- Install the new center console. Make sure you plug in all the connectors including the rear defroster connector. If equipped, plug in the the LED connectors for the security system.

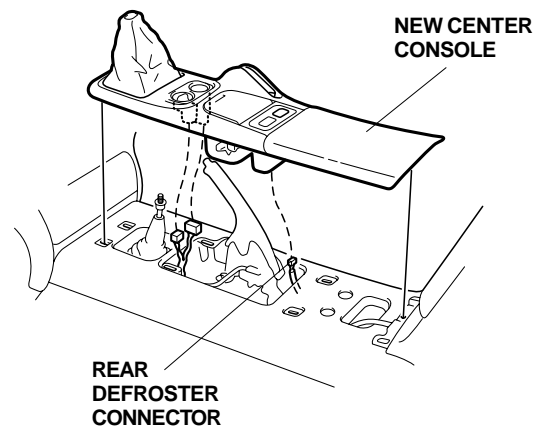

21. Replace the front strikers:

- Remove the spotlight lens and the spotlight (two screws, and unplug the connector).
- Remove both sunvisors (one screw for each sunvisor).
- Remove the left and right front pillar trims. Be careful not to break the tabs at the top of the pillar trims.
- Remove the front roof rail trim (two clips).

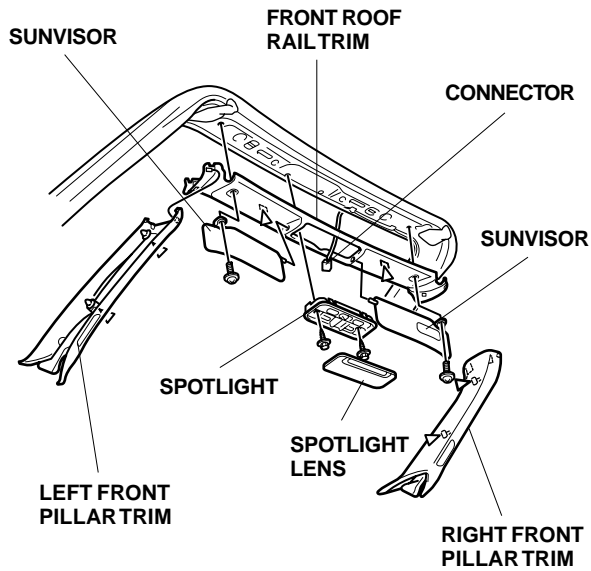

- Replace the front strikers with the ones in the kit. Torque the striker screws to 9.8 N•m (7.2 lb-ft).

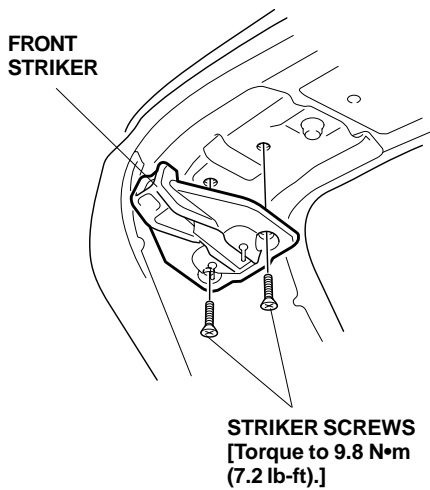

22. Install the left body side catcher:

- Locate the area where the convertible top frame and the corner gusset meet. Using a hammer and a center punch, bend the corner gusset outward until it follows the contour of the convertible top frame.

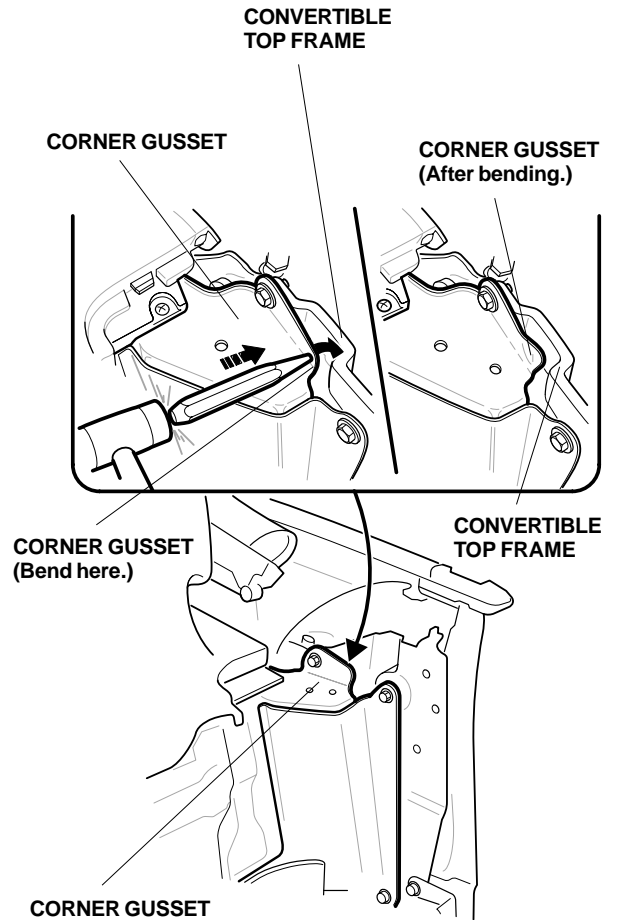

- Install the left body side catcher into position over the corner gusset, and install two 6 x 18 mm bolts and two 8 x 20 mm mounting bolts. Torque the 6 mm bolts to 10 N•m (7 lb-ft), and torque the 8 mm bolts to 30 N•m (22 lb-ft).

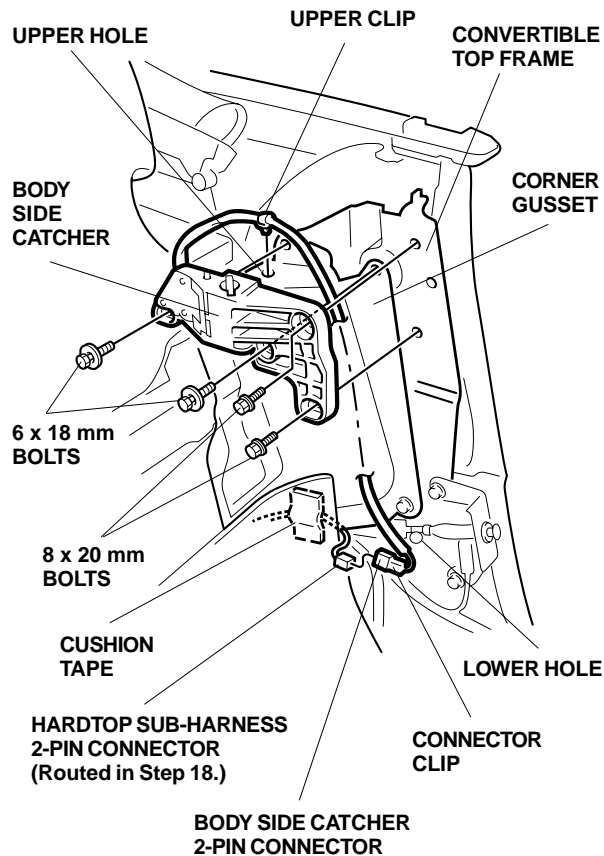

- Route the 2-pin connector from the left body side catcher down in front of the catcher, and plug it into the hardtop sub-harness 2-pin connector (routed in step 18).
- Attach the upper clip on the wire to the upper hole in the body, and attach the connector clip to the lower hole in the body. Tuck the harness under the carpet.
- Secure the sub-harness with one cushion tape in the area shown.

23. Repeat step 22 to install the right body side catcher in the same way, except there are no wires to connect on the right side of the vehicle.

Installing the Hardtop

24. Install the hardtop:

- Check that the rear lock pin handles on the hardtop are in the forward (**unlock**) position, and the holder plate mounting bolts on each side are loose.

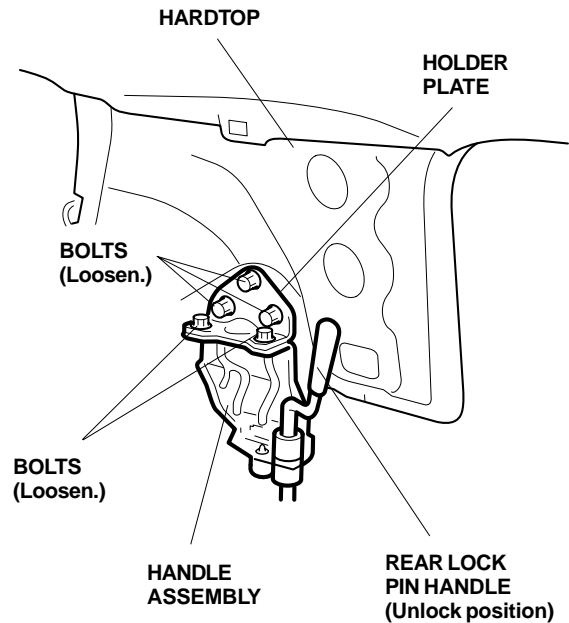

- Open the front lock handles. With the help of an assistant, gently set the front of the hardtop on the windshield frame, and align the front lock handles with the front strikers. At the rear of the hardtop, fit the roof lock pins through the holes in the body side catchers.

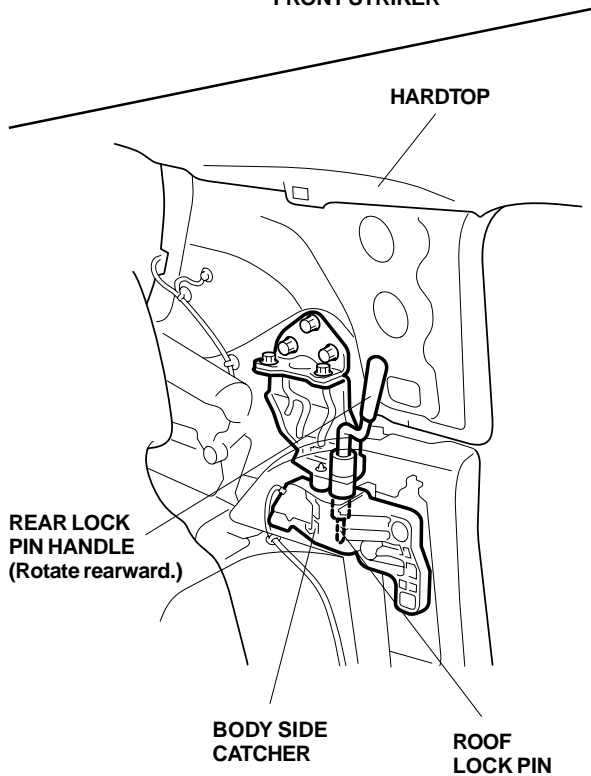
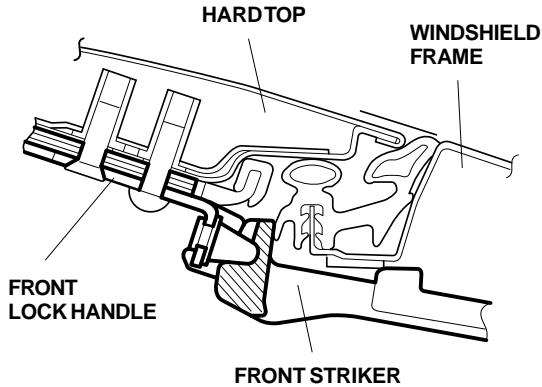

- Lock the front of the hardtop into position with the front lock handles, and lock the rear of the hardtop by rotating the rear lock pin handles rearward into the **lock** position.
- Tighten the holder plate mounting bolts securely.

Adjusting the Weatherstrip Gap

25. At the front of the hardtop, make sure the hardtop is within the measurement shown; if not, you will need to remove and reshim the front lock handles.

SHIM (thickness 1 mm)
Standard is 3 shims.

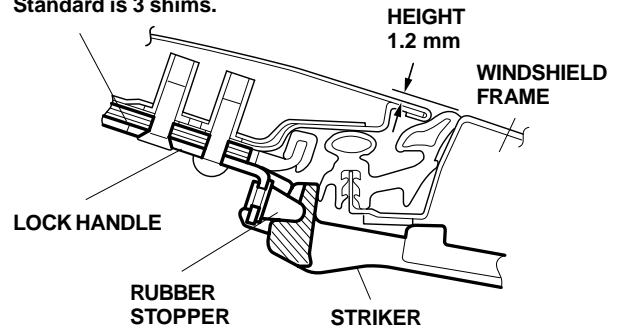

26. At the rear of the hardtop, measure the gap between the hardtop and the body at the location shown. If the gap is incorrect, adjust the weatherstrip gap:

- Unlock the front lock handles.
- With the rear lock pin handles in the **unlock** position (handles forward), loosen the holder plate mounting bolts.
- Lift up the hardtop, and reposition it back on the vehicle.
- Lock the front lock handles.
- With the hardtop resting in position with the lock pins in the catchers, but **not** locked, tighten the holder plate mounting bolts.
- Rotate the rear handles to the **lock** position, and recheck the gap. Repeat the entire adjustment procedure until the proper gap is obtained. If necessary, the rear handles can be rotated slightly to increase or decrease the gap.

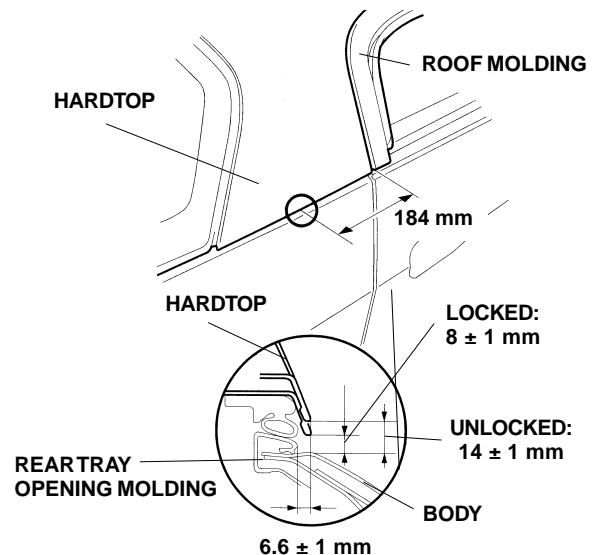

27. Check the door glass weatherstrip at the top and side to make sure that it contacts the glass evenly. If necessary, adjust the roof retainer. If window glass adjustment is required, refer to the service manual. Repeat for the other window.

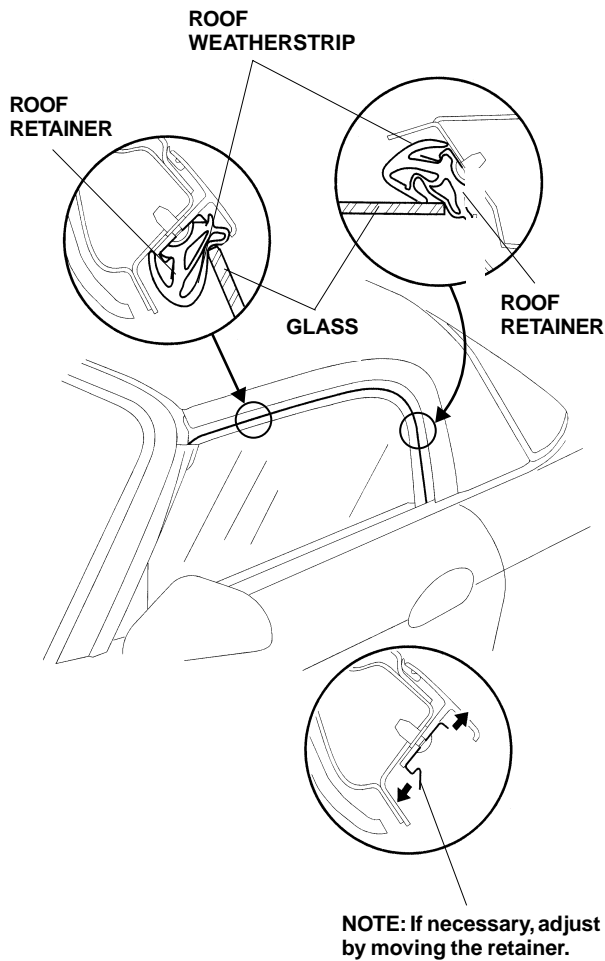

28. Check for water leaks by driving the vehicle through a car wash, or by spraying the vehicle with a hose. If you find a leak, repeat steps 26 and 27 until fixed.

29. Install the rear roof pillar trims:

- Peel back part of the hardtop side trim.
- Fit the rear roof pillar trim in place, and make sure the tabs fit into the holes in the hardtop.
- Snap the rear roof pillar trim into place, and reinstall the side trim over the rear roof pillar trim.
- Remove the adhesive backing from the inside of the trim end cap, and attach it to the rear side trim.
- Repeat on the other side of the vehicle.

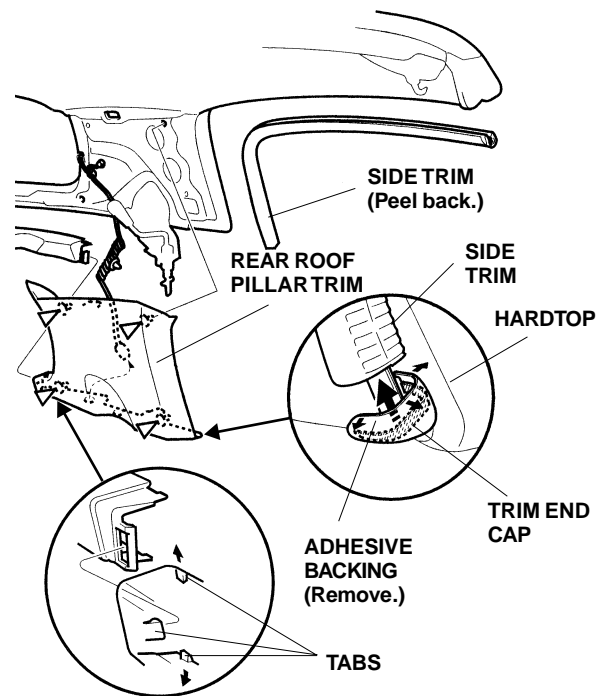

30. Route the 3-pin connector with rubber boot (routed in step 18) through the empty hole in the new left rear side trim, and seat the rubber grommet in the hole. Install the new left rear side trim.

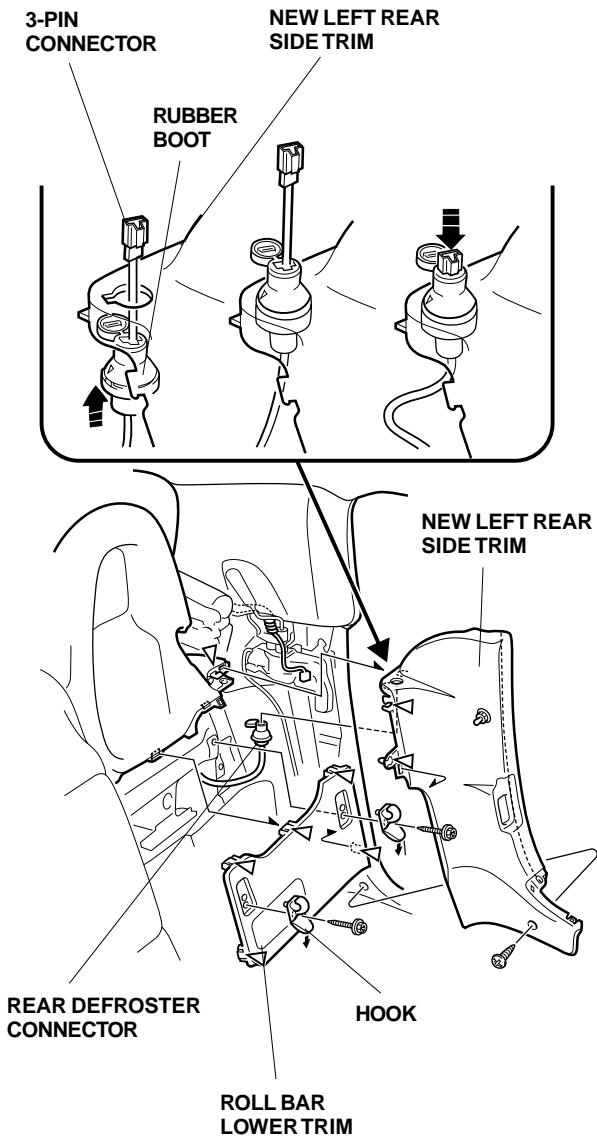

31. Install the new right rear side trim.
32. Reinstall both roll bar lower trims and hooks.
33. Reinstall the left and right door sill trims and the left kick panel.
34. Plug the rear defroster harness into the 3-pin connector on the left rear side trim. Place the clip on the defroster harness into the hole in the left rear side trim. Check that the harness is not pinched by the hardtop.
35. Install the information label onto the left rear side trim:
- Using isopropyl alcohol on a shop towel, clean the area where the information label will be attached.
 - Remove the adhesive backing from the information label, and attach it to the left rear side trim in the area shown.

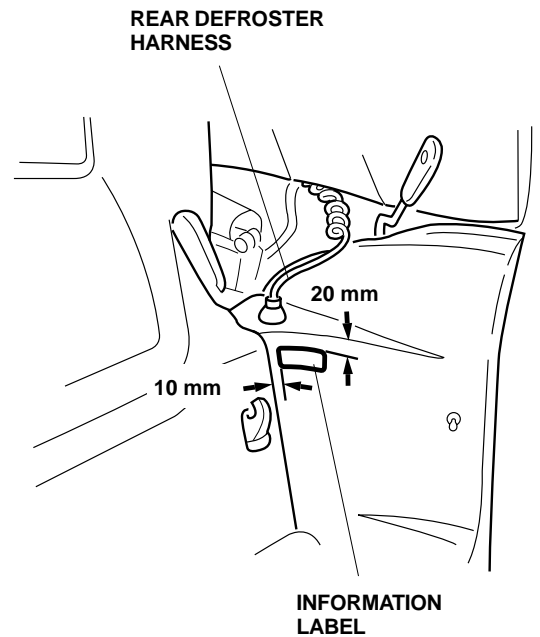

36. Install the VIN plate on the inside center of the hardtop:

- Using isopropyl alcohol on a shop towel, clean the center of the hardtop where the VIN plate will be attached.
- Remove the adhesive backing from the VIN plate, and attach it to the hardtop in the area shown.
- Press firmly on the VIN plate with the palm of your hand.

